



Installation Judgebook 2014/2015



written by
Jan Schleicher &
Werner Rothschof

This judge book is a guideline how to proceed during an EMMA Installation judging.

It will be updated continuously and the updated version is always available at www.emmanet.info

Presentation

Points are given for the quality of the presentation and documentation used during the 7(14) minute presentation. All parts of the installation should be documented by photo-log. Highest points will be awarded when the documentation is self-explaining so the judges do not have questions about the development of the system. Lower points will be awarded for just showing some pictures without verbal comments by the competitor. The media used for the presentation does not influence the score – only the quality of the presentation and documentation counts Please remember that the presentation is very important. This is what the judges will base their judgment upon. The details of the installation should be made clear during presentation. The judges should not have to look for the details themselves. What cannot be seen cannot be judged!!

- **be polite**
- **don't disturb the competitor**
- **listen to the competitor**
- **warn the competitor when he is**
- **focusing too much on detail (1 time)**
- **missing pictures will end up in a triple penalty**

Basic Presentation

A wiring-diagram containing the sizes of the wires & the fuses, (Photo-)Documentation of the main power circuit and the fuses and a presentation held by the competitor.

4-5points

relatively fluent presentation photo log with requested information and wiring diagram with the requested info

1-3 points

Poor or no wiring diagram, poor or no documentation / photo-log of main power circuit & fuses presentation barely fluent.

0 points

No presentation and no documentation

For installation judging keep in mind for 4.3.1.:

The judges will check by physical inspection and/or photo log. For any component that is not fixed or not documented (there are only two possibilities: fixed or not fixed), three (3) points will be deducted.

So if some components are not accessible they should be documented in the photo log. But no deduction for missing pictures in presentation.

Sample Pictures:

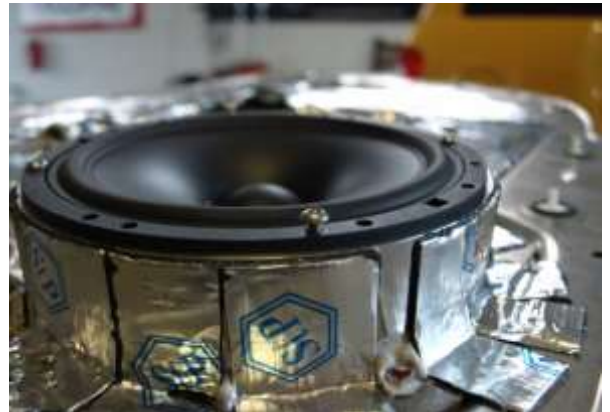
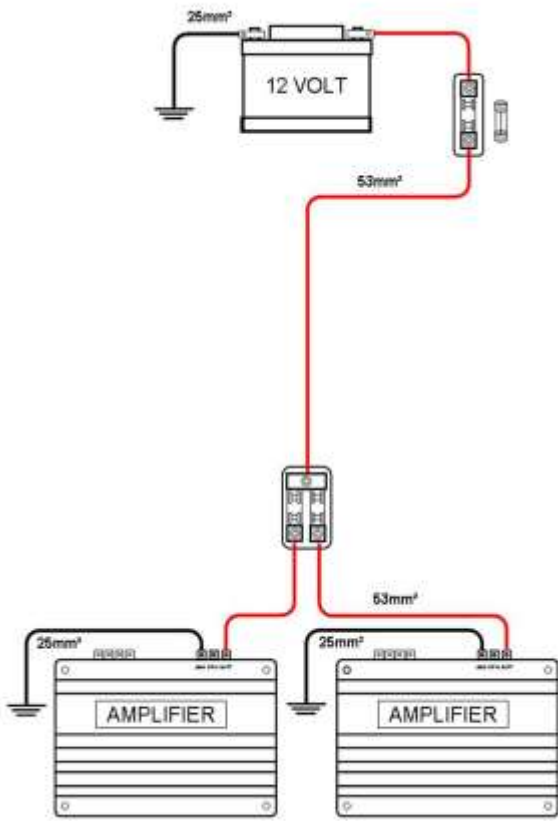

Please watch out!

We do NOT judge craftsmanship here, this is only the presentation, even a bad install can be perfect documented.



Progressed Presentation

It is for sure a sign of a perfect presentation to be able to explain the whole car and system within 7 minutes. No need to be focused on every detail, if there is a proper presentation book. To score full points a presentation book in native language and in a common EMMA language is necessary.

Based on the documentation requested in paragraphs 4.1.1 to 4.1.3,

additionally requested is:

- a well organized documentation
- Relevant details explained by quality photos
- not only describing the finished “product”
- but also the development – not missing any relevant step not to forget any components of the installation
- a fluent and logical presentation within the available presentation time

3-5 points

Fluent, logical and detailed presentation detailed documentation including quality photo log not only showing the finished product, but also describing the development of the system, not missing any relevant step. All parts of the installation should be available on detailed photo documentation for checking

1-2 points

relatively fluent presentation documentation including photo log (with gaps and deficiencies in organization of the documents) available

0 points

No presentation and no documentation / no performance better then requested under 4.1.1

Please watch out!

We do NOT judge craftsmanship here, this is only the presentation, even a bad install can be perfect documented.

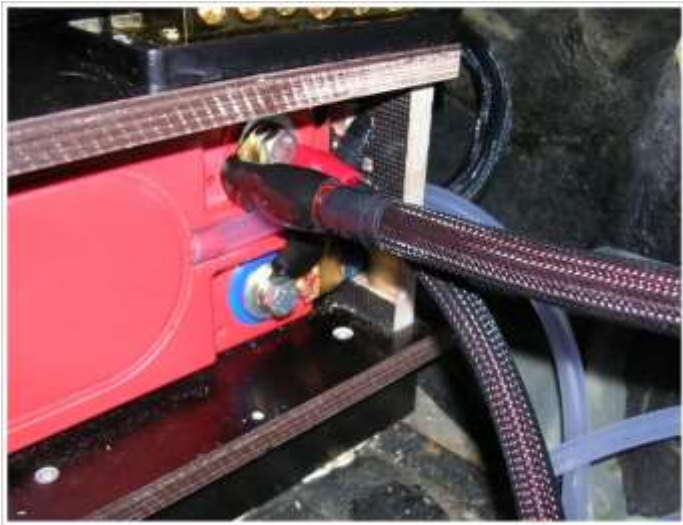

Documentation

All components not accessible or hidden from view should be explained in the documentation.

What is included:

- Black boxes
- Crossovers (passive and/or active)
- Speakers behind door panels or dashboard grills
- Additional battery
- Etc.

The judges deduct one (1) point for each component that is not documented. All wires to components not accessible or hidden from view should be explained in the documentation.

What to look for:

- Behind source unit
- Black boxes
- Crossovers (active and/or passive)
- Behind/under covers, racks, carpets etc.
- Power / Ground wires
- Speaker wires
- Signal-cables (including cables to multi-media-screens, remote controls, etc.!!!)
- Control-cables (bus-cable to processors etc.)
- Connections to additional battery
- Etc.
- watch out for:
 - Head unit DC/DC Converters
 - Head unit Black Boxes

watch out for:

Head unit DC/DC Converters

Head unit Black Boxes



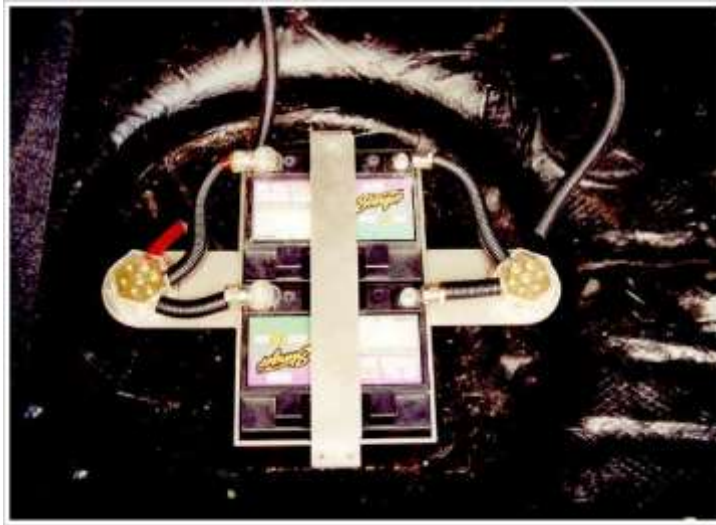
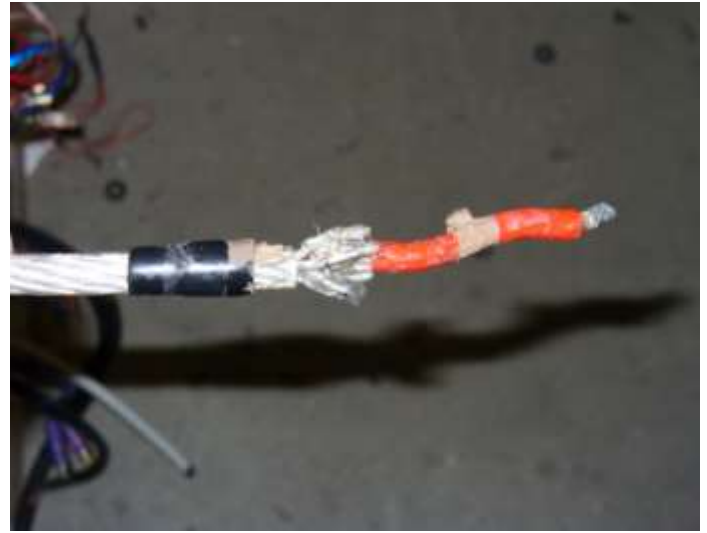

Based on the documentation requested in paragraphs 4.1.1 to 4.1.3, additionally requested is:

- A well organized documentation
- Relevant details explained by quality photos
- Not only describing the finished “product” but also the development – not missing any relevant steps Not to forget any components of the installation
- A fluent and logical presentation within the allocated time

1 point

Fluent, logical and detailed presentation within the time limit.

1 point

Detailed documentation including quality photo log explaining relevant details

1 point

documentation not only showing the finished product, but also describing the development of the system, not missing any relevant step.

1 point

Having all parts of the installation available on detailed photo documentation for checking.

1point

Well and logical organized documentation including photo log (without gaps and deficiencies in organization, of the documents

0 points

No presentation and no documentation/no performance better then requested under 4.1.1.

Presentation to the Public

Presentation to the public (0 or 10)

A car audio competition is a relatively quiet but a very interesting Event. To allow spectators to see what equipment is installed in the cars and to get some idea about the details of the installation, the cars should be displayed to the crowd.

Points will be awarded, when the following is made available for visitors during the whole competition day/Event:

A display of the installed equipment (can be a diagram attached to the inside of a window)
Showing off of the car – at least the trunk (or if nothing is installed there the front doors) should be open.

The competitor (or friend) is available for explanations and allows people to listen to the car by request or having the door open and the system playing in a low volume.

Additionally, it would be nice, if the material/equipment used as a documentation to the installation judges (laptop, DVD, photo logs, samples etc.) is also available for visitors

How to judge:

The installation judges will award the points during their judging process.

During the entire competition, the head judge or a designated judge will, in irregular intervals, have a walkabout and keep a record of the status of the competition cars. At the end of the competition day and/or before prize-giving ceremony, these records will be analyzed and if the above requested points were not fulfilled more than 50% of the time, the score will be adjusted to zero (0) points.

Exceptions:

Active judges or EMMA-staff (on this Event) will not be judged for presentation to the public besides judging

Bad weather or other circumstances during an Event may influence the display of equipment, showing off and availability of the competitor for offering people to listen to his system. In this case, it is up to the discretion of the Event director to decide how to proceed for all competitors.



Wiring/Fusing

Fused System (0 or 10 points)

The fusing of the power cable is to protect the car in case of a short circuit. If there is no fuse installed the risk is that the cable will burn before the fuse blows and so may cause severe damage or fire. Therefore, all power cables related to the car audio system must be fused except the cables that are used to connect the starter motor and/or alternator to the battery, which is used to operate the vehicles electric system.

The judges will follow the route of the power cables in the system. Every power cable must be fused. If the remote cable is a control cable, no fuse is necessary. If it is connected to a relay, the power cable to this relay should be fused.

Any power cable fused properly (SQ 0 or 10, ESPL max 15 points)

Furthermore, any fuse related to the car audio system must be of proper size. If the fuse is too big, the risk is that the cable will burn before the fuse blows and so may cause severe damage or fire. The fuse size is directly depending to the wire gauge of the power/ground cables installed.

Every power cable related to the audio system must be fused properly according to the fuse table. Exception: If the OEM-wiring-harness together with a DIN/ISO-adapter to the source unit is used, the fuse must not be bigger than original (has not to be according to fuse table!) or can be smaller. All fuses should be physically available for inspection, the size of the cables should be visible or described in the documentation.

Ground cable will be taken into consideration! If the ground cable is smaller than the positive cable, the ground cable will determine the fuse size! (Example: positive cable 50mm², Ground cable 20mm² => max. fuse size refers to the 20mm² Ground cable)

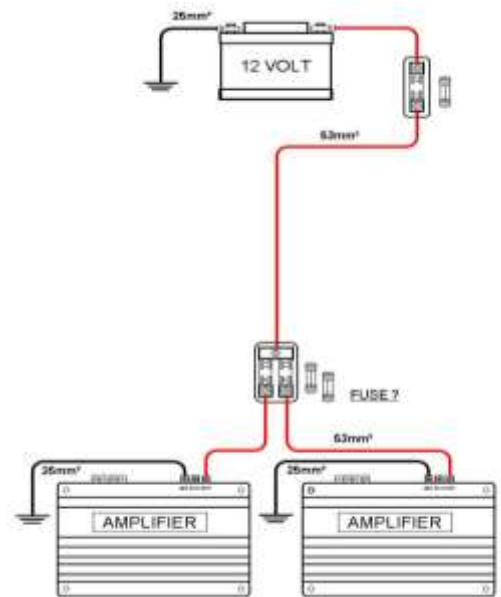

Do not forget to consider the ground cable from the battery to the vehicles chassis. Ideally additional ground cable should be installed that is equal to the mm² of positive cable feeding the car-audio-system. The sum of the fuse rate of all cables from the battery feeding the audio system (except OEM-wiring-harness) cannot be higher than the maximum fuse rate according to fuse table allowed for the size of the ground cable. To make judging easier in the case that the vehicles ground cable is without modification/addition, the OEM-ground cable will be calculated with a spare of 6 mm² for the car audio system = 40 Amps.

Anytime the gauge (mm²) size of a power circuit changes, the fuse size has to be appropriate to the smallest gauge size in that circuit. Otherwise it has to be fused within 40 cm from the point of the diameter reduction and before it passes through a metal panel before the fuse. Please note that the circuit includes both positive & negative cable!

5 points to be deducted per failure



Any power cable of the system connected to a positive battery post (including possible extra batteries) must be fused within 40 cm from the battery post (from terminal to terminal). If the cable passes through any metal panel before the fuse, it must be properly protected with a grommet (not only tubing/sleeve!). There must be no risk for the cable to connect to metal before the fuse and this rule applies only to an additional battery in a sealed metal box. This includes cabling for external charging systems/service connections etc. that are permanently installed.



For any additional battery used, the cable length/length of metal bars between the positive posts must be shorter than 40 cm; otherwise they should be properly fused

Factory dual battery systems may not have any fuse (or protection) between the batteries. It is up to the competitor to prove the original installation of his vehicle. If the OEM-installation was not changed, any additional fuse or protection is not required. Raw metal material such as metal bars, etc. instead of wire with an equivalent surface can be used

The judges will check the installation. If all of the above points are fulfilled, only one (1) deviation of the above described will result in 0 points.

In SQ and Multimedia all 3 criteria (4.2.1.1 , 4.2.1.2 and 4.2.1.3) must be fulfilled to get full points. The maximum in these categories are 10 points. The judges will check the installation, if all of the above points are fulfilled, only one (1) deviation of the above described will result in 0 points.

Cable size (mm ²)	Cable size (AWG)	Max fuse size (A)
0,5	20	5
0,75	18	7,5
1	17	10
1,5	15	15
2,5	13	25
4	11	30
6	9	40
8	8	50
10	7	60
16	5	80
20	4	100
25	3	125
30	2	150
50	0	200
70	000	250
95	0000	300

Please note that the above fuse rates are what the maximum fuse size is allowed to be! Not what the fuse should be. Smaller fuse sizes are always acceptable.

Examples:

- A 50 mm²/AWG 0 cable must not have a fuse larger than 200 ampere.
- 80 A fuse on a 50 mm² cable is below tolerance, but there could be a risk the fuse will blow when the system is cranked up (depending on the power draw).

Please watch out this rule is not applicable if there is on OEM Amplifier and the OEM wiring used.

Ground cabling

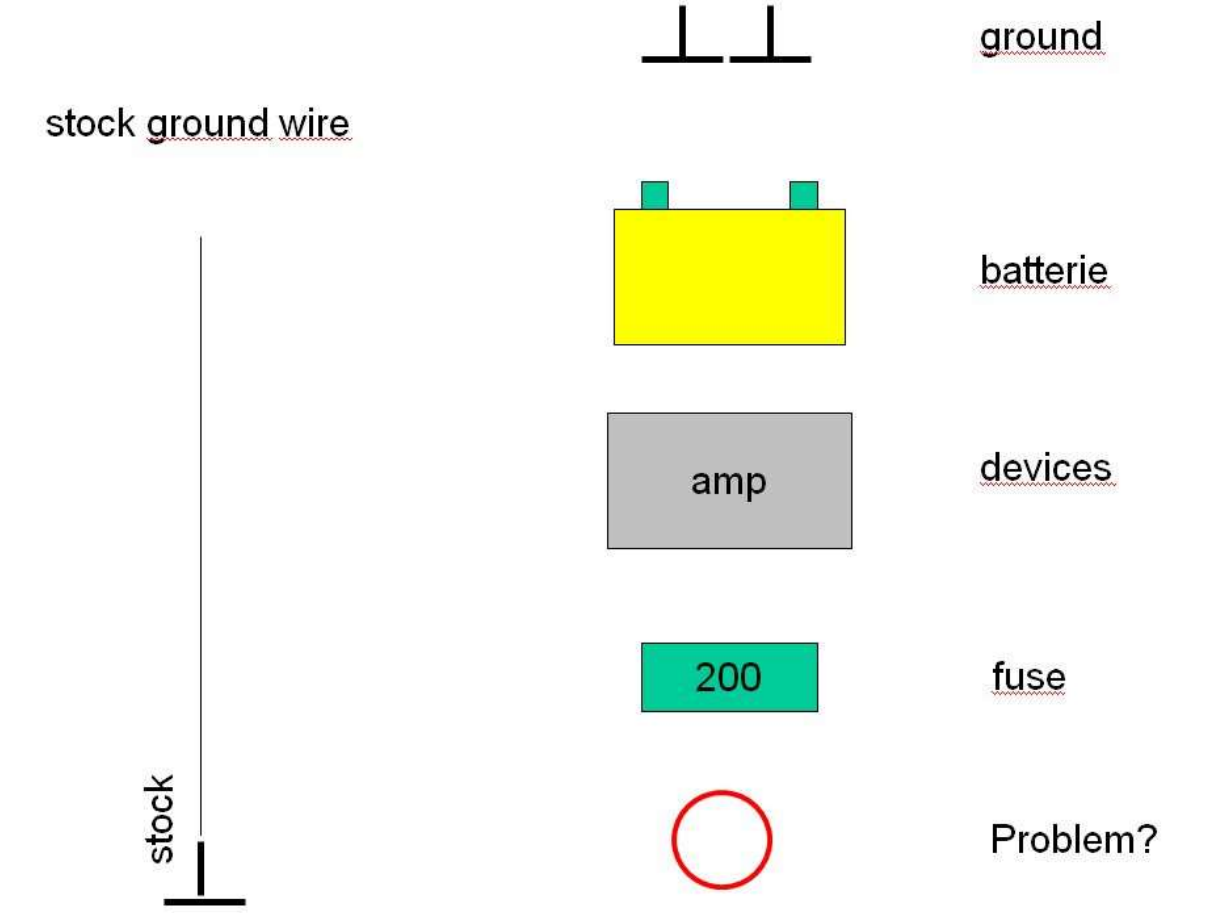

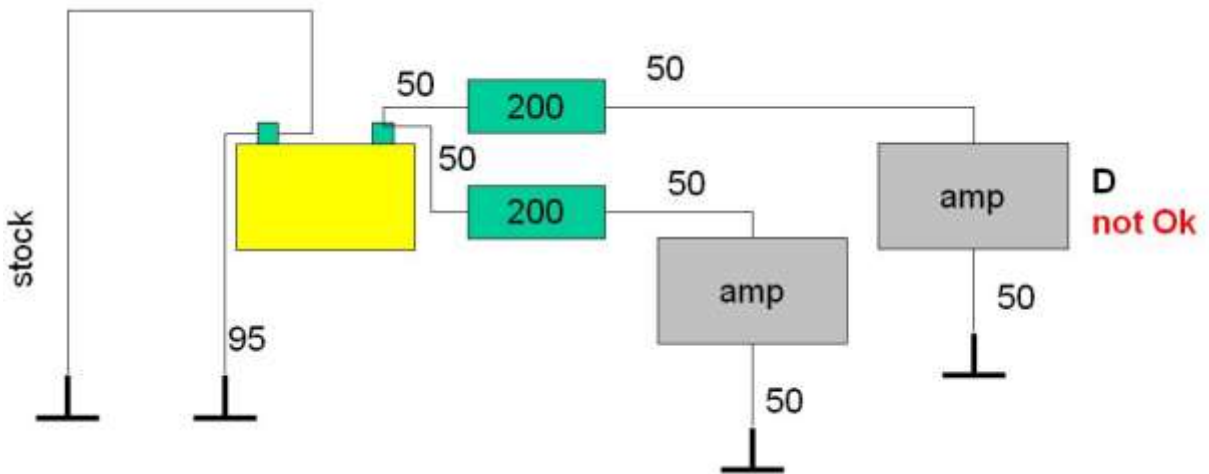
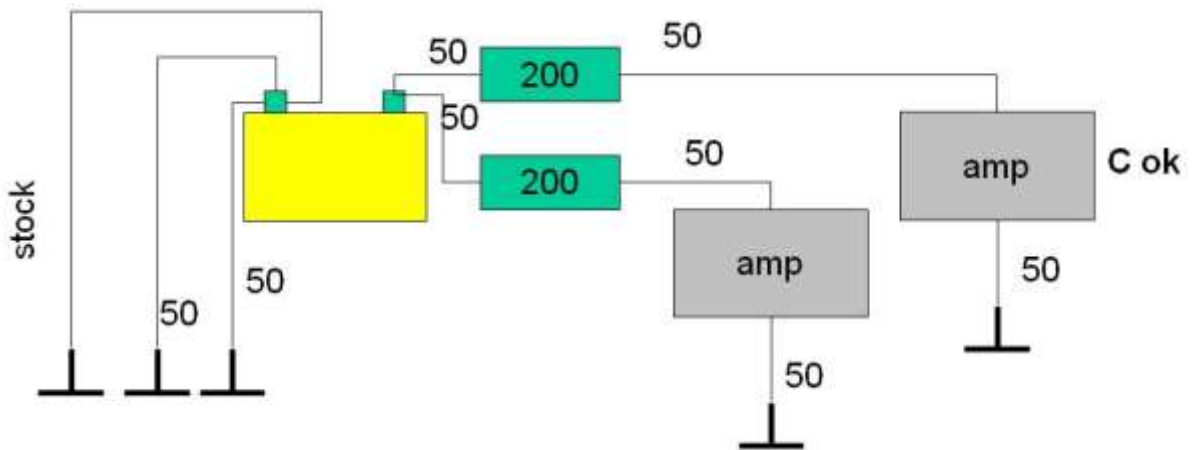
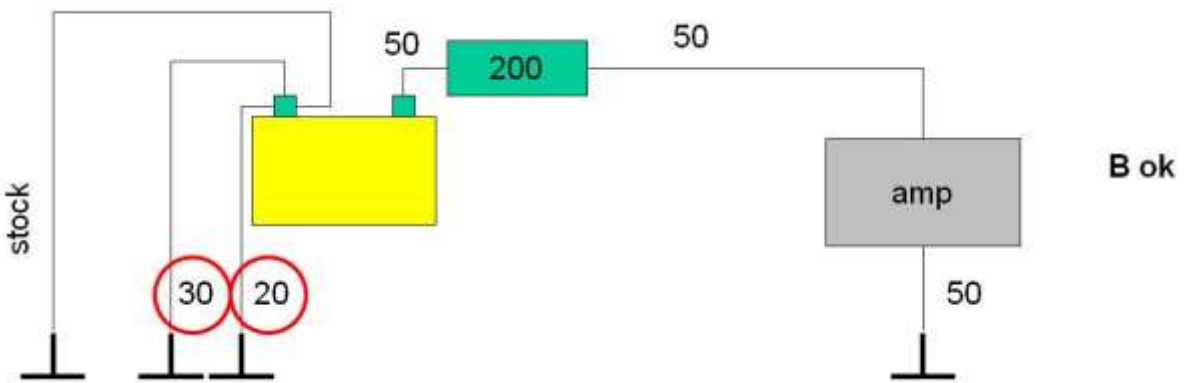
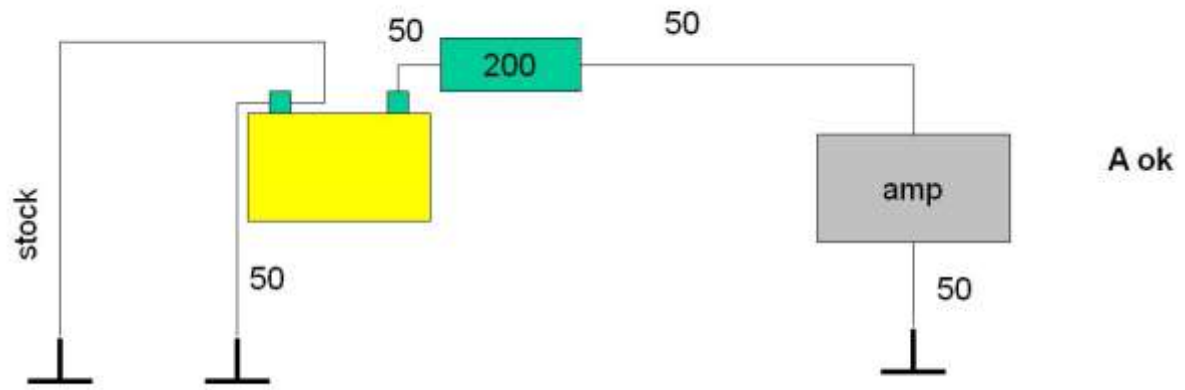

Wiring

4.2.4. Wires properly terminated (0 or 5)

All wires must be properly terminated at the connecting point, for example at the battery post (including the battery post itself!), the amplifier-terminal, distribution blocks, power capacitors, speaker-terminals etc. Each termination should be solid and free of any fraying wire strands.

What to look for:

- Power / Ground wires
- Speaker wires
- Signal- cables
- Control- cables

The judges will check by physical inspection and/or the documentation. Only one loose or poorly executed wire connection, or a missing connection in the documentation (not requested in Entry) in will result in 0 points. In Experience Category only the Main Power circuit is taken into consideration



4.2.5 Any wire termination properly protected (0 or 5)

All connections of wires to terminals related to the car-audio-/-mobile-media-system must be protected from short circuit. All positive connections (and surfaces) and all speaker connections must be covered with a non-conductive material.

Furthermore all connections of wires to terminals related to the car-audio-/-mobile-media-system must be protected against corrosion if located in a potentially corrosive environment, for e.g. speaker-connections in the doors, power connections in the engine compartment, etc

If a detachable panel must be removed to reach the connection (e.g. a plastic or wooden cover over a battery), it will be considered as proper protection from a short circuit (but don't forget the risk for corrosion). The engine hood itself is not sufficient protection! If the wire to the alternator is changed, the connection to the alternator must be protected from a short circuit. Some terminals at speakers may not require extra protection (e.g. spring loaded type, types where the wire will be fixed by a screw). Cables related to the Audio / mobile media system should be terminated using precious metal (e.g. gold or titanium plated connectors, etc.) or other means (e.g. anti corrosive lubricant, soldering, heatshrink-tube, etc.) to prevent corrosion.



There are some kind of metals on this planet which are "NON-Corrosive" e.g. Gold, Titanium, Tin. Here is no special attention needed.

If the connector at the speaker is Gold plated and the Copper wire is soldered properly with Tin, then there is no need to build a cover or something else. The usage of shrink tube or similar is enough to protect. A sealed enclosure around the speaker is also enough to protect from corrosion. There is no need to protect the leads between terminal and VC and the speaker.



The judges will check by physical inspection and/or the documentation. Only one loose or poorly executed wire connection, or a missing connection in the documentation (not requested in Entry) in will result in 0 points. In Experience Category only the Main Power circuit is taken into consideration

The judges will check by physical inspection and the documentation. All relevant spots should be accessible or shown in the documentation. If the positive battery post and any other termination of the cabling can be touched (watch out: fingers are flexible!) or only one unprotected cable termination is detected physically or in the photo documentation or missing in the documentation, the score will be 0 points.

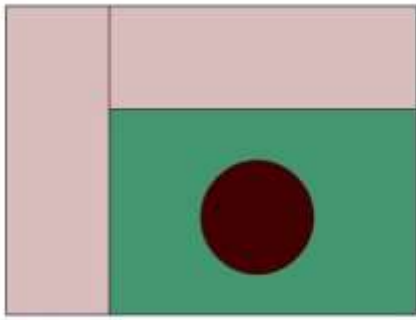

Not sufficient

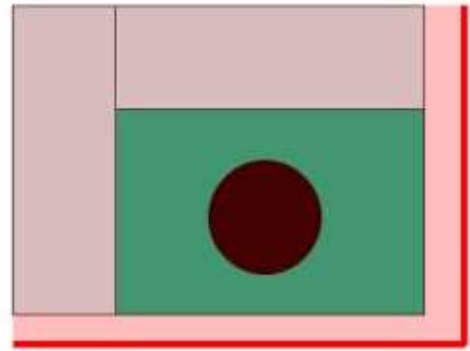

sufficient

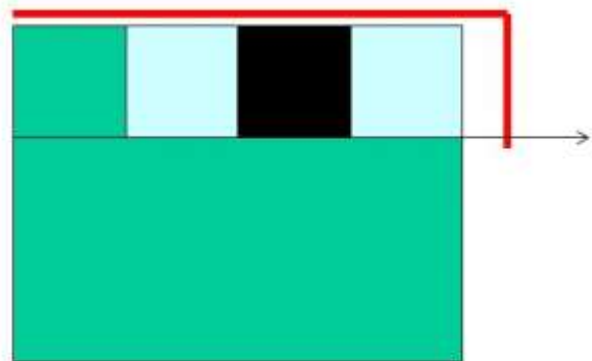
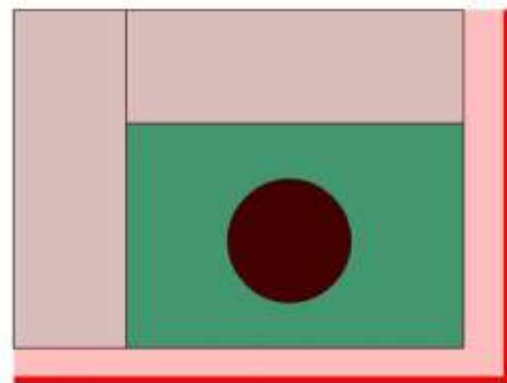
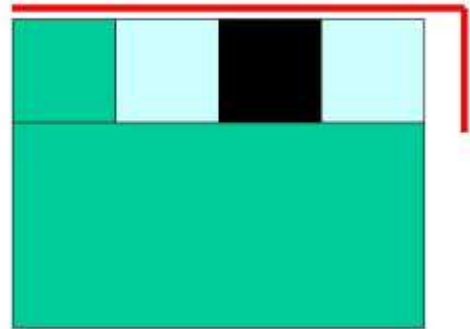
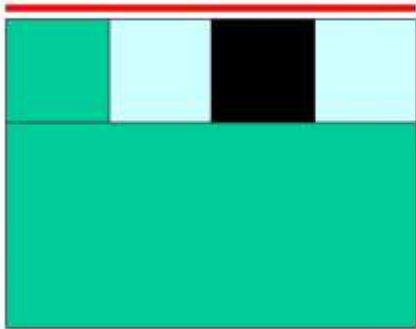

sufficient

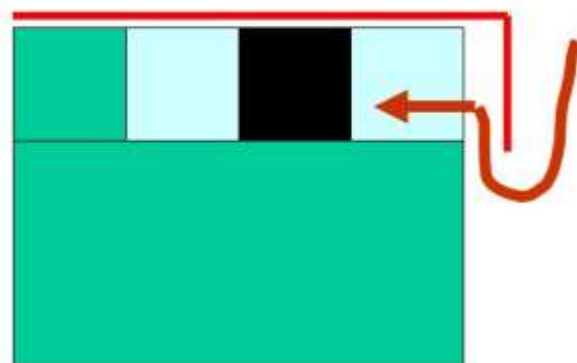

This way of judging is not according to the Rulebook.



NO deduction here ! if the fuse block is covered with the original carpet



4.2.6. Wires protected from damage (0 or 5)

The **system wiring** must be properly protected from hazardous elements like sharp metal edges, heat radiation, moisture, moving parts, critical mechanisms and wear by vibrations, etc.

EMMA recommends routing the wires away or properly protecting them from potential noise-producing components like critical existing vehicle wiring, engine management computers etc. to avoid eventual radiated noise problems. All wires passing through a metal panel must be protected by a grommet and/or protective sleeve/tubing. This includes also speaker wires routed into doors etc.

What to look for:

- Power / Ground wires
- Speaker wires
- Signal-cables
- Control-cables

The judges will check either by physical inspection or by the documentation. All relevant spots should be accessible or shown in the documentation. Zero (0) points will be scored if only one wire is neither accessible nor documented, not protected for heat radiation (e.g. mounted to close to the exhaust manifold), exposed to mechanical hazards (critical mechanisms, fans etc.), without proper protection, etc.

The judges will check either by physical inspection or by the documentation. All relevant spots should be accessible or shown in the documentation. Zero (0) points will be scored if only one wire is neither accessible nor documented, not protected for heat radiation (e.g. mounted to close to the exhaust manifold), exposed to mechanical hazards (critical mechanisms, fans etc.), without proper protection, etc.

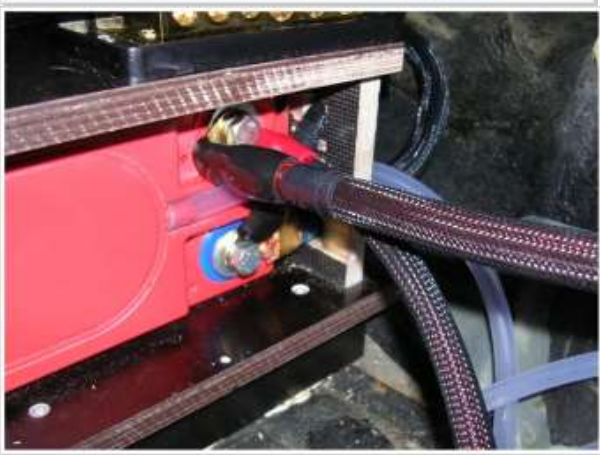

4.2.7. Interiour wires hidden from view (0 to 5)

All system wiring in the Interior of the vehicle should be hidden from view.

What to look for:

- Power / Ground wires
- Speaker wires
- Signal-cables (including cables to multi-media-screens, remote controls, etc.!!!)
- Control-cables

The judges will check by visual inspection, sitting in an upright position on the drivers / passenger's seat with the front doors open. The judges will verify that no wires under the dashboard or passing into doors are visible. The judges deduct one (1) point for each wire or bundle of wires visible.

A wire from the A-pillar to the door will be considered as invisible if the coverage (grommet e.g.) looks like original.

Only cabling that is part of the Audio/Multimedia System are to be considered.

Portable Navigation System and Mobile Phone Chargers are not part of an Audio/Multimedia system. Visible cables behind the B-pillar will not be considered (e.g. amplifier installation in a station wagon) Cables or bundles of cables in snakeskin or plastic tubing etc. are considered "not hidden from view" and will lead to point deduction!

If for design purposes matching the rest of the installation theme cables are covered by transparent material within the view of the judges, they will be considered as "hidden from view"

USB or iPod cables or connectors for these devices will not be taken into consideration when judging installation.

For multimedia categories this is judged from the sound judging position (not always the front seat!).



Installation

4.3.1. Components securely mounted (0 – 20)

All components belonging to the stereo / Multimedia system should be solidly fixed to their mounting panels and/or to the vehicle. This includes equipment that is able to generate a signal but maybe not in use to reproduce the EMMA-CD, e.g. Playstations, DVD-players, etc. If this equipment is only temporarily in the vehicle and not installed, it should be taken out of the vehicle before the installation judging starts.

What components to check:

Front end

- Operator panel
- Source unit
- Black boxes
- Screens
- CD/DVD-player / changer
- External D/A converters
- Remote controls

Amplifiers

Speakers

Other Devices

- Pre Amp
- Line drivers
- Crossovers (passive or active)
- Signal-processors
- Batteries (original as well as additional)
- Multiple battery charge regulators/ Remote Relays
- Fuses / fuse blocks / power distribution blocks
- Capacitors
- Etc. (including all other devices not mentioned above - through which the audio signal will pass once it leaves the source unit until it reaches the speaker)



Judges should not use force when judging securely mounted components. It depends on what component is being checked according to the weight of it (e.g. a tweeter in the a-pillar doesn't have to be fixed as tightly as a subwoofer to its box in the trunk). The method for fixing doesn't matter as long as the component is properly fixed (e.g. could be screwed to a wooden plate or glued as well as welded to a steel plate) Grills or any other protective elements will not be checked for proper fixing. If a front end with detachable faceplate is installed, it might be that the faceplate / detachable part has some play. If so, the judges will take away this part and check the installation of the remaining unit.

Which component has to be judged?

A mass storage device (USB Stick, MP3 Player, cellular phones ...) - wiring, fixing, first optic impression, design passenger compartment and craftsmanship will not taken into consideration if the competitor is using CD or DVD as source for EMMA competition. If the competitor is using such a device as source for competition or requests bonus points for such a device wiring, fixing etc. must be according to the EMMA rules.

A digital car bus interface (CAN, LIN, SAE or similar) needs no fuse for ignition output if the competitor can prove that the interface is feed by

the OEM wire loom or another properly fused wire.

Rear Seat Entertainment will only be considered during judging if it is A/V connected to the SQ System. If Bonus points are requested, Rear Seat Entertainment has to be in line with the rulebook!

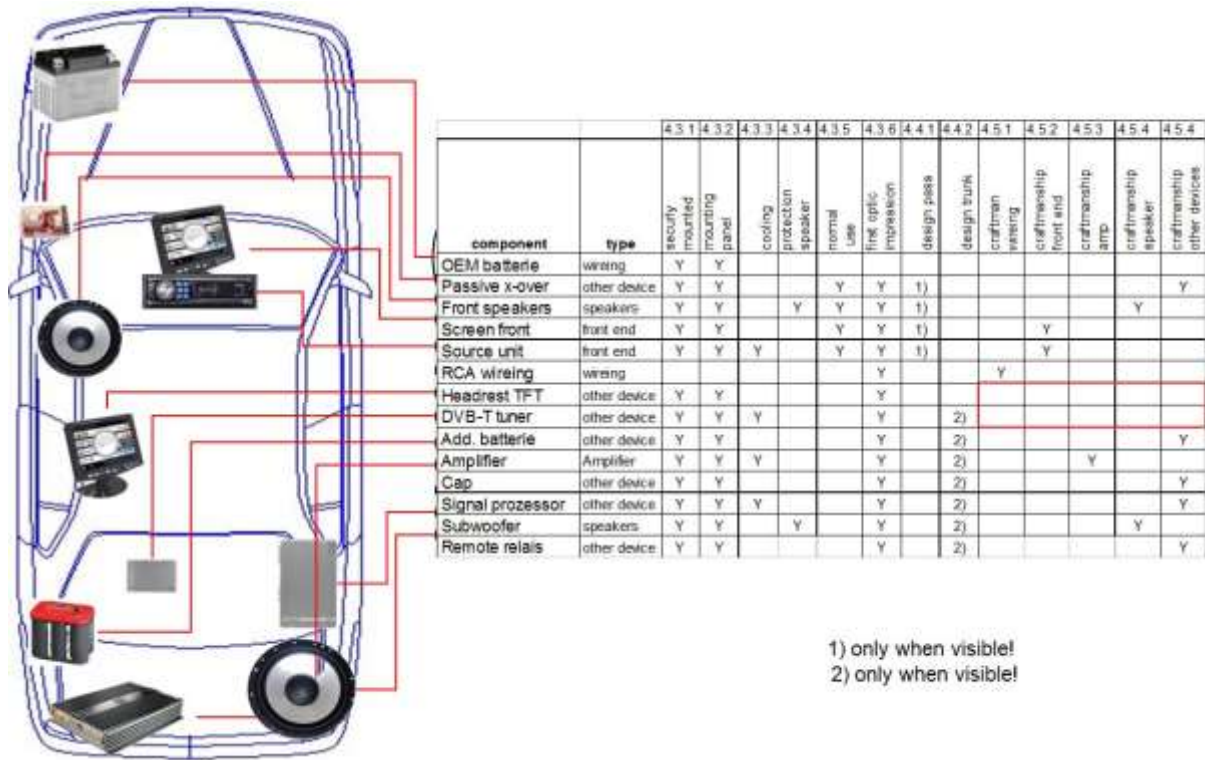

1) only when visible!
2) only when visible!



Fixed or not fixed is here the question

4.3.1. Components and mounting panels securely mounted (0 – 20)

All mounting panels supporting the components belonging to the stereo / Multimedia system should be solidly installed to the vehicle. The judges will check by physical inspection and/or photo log. For any mounting panel that is not fixed or not documented (there are only two possibilities: fixed or not fixed), three (3) points will be deducted

What mounting panels to check:

Front end

- Operator panel
- Source unit
- Black boxes
- Screens
- CD/DVD-player / changer
- External D/A converters
- Remote controls

Amplifiers

Speakers

Other Devices

- Pre Amp
- Line drivers
- Crossovers (passive or active)
- Signal-processors
- Batteries (original as well as additional)
- Multiple battery charge regulators/ Remote Relays
- Fuses / fuse blocks / power distribution blocks
- Capacitors
- Etc. (including all other devices not mentioned above - through which the audio signal will pass once it leaves the source unit until it reaches the speaker)



Fixed or not fixed is here the question?



1. Judges should not use force when judging securely mounted components. It depends on what component is being checked according to the weight of it (e.g. a tweeter in the a-pillar doesn't have to be fixed as tightly as a subwoofer to its box in the trunk).

2. The method for fixing doesn't matter as long as the component is properly secured (e.g. could be screwed to a wooden plate or glued as well as welded to a steel plate).
3. Grills or any other protective elements will not be checked for proper fixing.
4. If a front end with detachable faceplate is installed, it might be that the faceplate/detachable part has some play. If so, the judges will take away this part and check the installation of the remaining unit.
5. External devices: as long as external devices which are able to play the EMMA recordings are turned off or disconnected during the judging process these devices will not be judged. This has to be proven by the competitor. The same rule applies for rear seat entertainment systems.
6. If a component is attached to a factory (original) panel and this panel is not properly fixed, points will be deducted (e.g. tweeter mounted to panel fixed with clips could be a bit loose)
7. Grills or any other protective elements and covers without mounted components will not be checked for proper fixing.
8. If the panel to which the components are mounted is movable, the judges will verify that this panel is fixed in the closed end position. Motorized installation elements (with the exception of motorized source unit displays) must be incapable of operating when the vehicle is started and shifted into "Drive" and the parking brake is released. Failure to meet this requirement will result in a 6 points deduction in this category.



Do not check if you can lift the car at the parts of the car audio system and you don't need both arms to check if the post at the battery is fixed or not.
 If the Tweeter is movable in a swivel housing which is fixed on the mounting panel no deduction.



4.3.3. Cooling (0 – 5)

Some components may require circulation of air to reduce the chance of overheating. If necessary, an additional cooling device (like fans, water-cooling, air conditioning etc.) should be present.

The judges should verify if cooling of the component is required or not – modern switch mode power supplies as used in actual processors or head units may work with an efficiency around 90% and may not produce heat. If no cooling is necessary, full points will be awarded.

Front end

- Source unit
- Black boxes
- External power supply
- External D/A converters
- Pre-Amplifiers

Amplifiers

Other Devices

- Signal-processors
- Multiple battery charge regulators
- Voltage converters (e.g. 12V to 14V, or 12V to 220V.
- Check specially in multimedia category)

watch out for:

Head unit DC/DC Converters

Head unit Black Boxes

The judges will look whether circulation of air is possible. If the competitor has taken sufficient steps for optimizing ventilation (holes, fans, water cooling etc.) or the components are in an open area/space, the points will be awarded. If there is no circulation of air possible / no cooling device is installed, two (2) points will be deducted per component (no negative scoring).

Example: two amplifiers in a sealed rack => 4 points deduction

If the Amps are mounted upside down, special effort for cooling is necessary.





How to protect a speaker ?

4.3.4 Protection of Speakers (0 to 5)

The judges will check whether all speakers (including subwoofers in the trunk) are protected from physical damage. One should not be able to touch the membrane with a round object with a diameter of 3 cm. There should be at least one protective element per speaker.

Protective bars with less than 3 cm gaps will get no deduction. Grill cloth with high tension but no support underneath is not considered as sufficient protection and will get points deducted.

Speakers, which are installed inside enclosures (and are not touchable) or with the baskets on the outside of the enclosure, do not need separate protection. The judges will verify the protection of the speakers as described above. Two (2) points deduction for each speaker not protected. (No negative scoring)

Grills or any other protective elements will not be checked for proper fixing.



The protection of speakers will be judge with a cylinder and with an angel from 90° between cylinder and the speaker mounting panel at the center position The cylinder should not be able to touch the **MEMBRAN**, but **NO** deduction when touching the **SURROUND**!

Also a "Phaseplug" is not part of the Membrane.

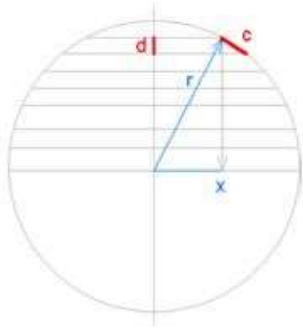

with a ball ?

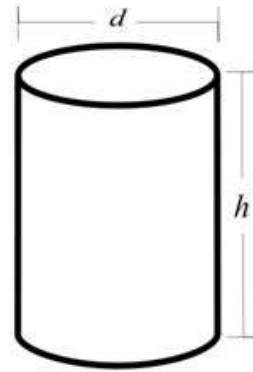

or with a cylinder?

A coax speaker is considered only as ONE speaker.

A Phaseplug isn't considered as a protective element.
So also in this case there must be at least ONE protective element.

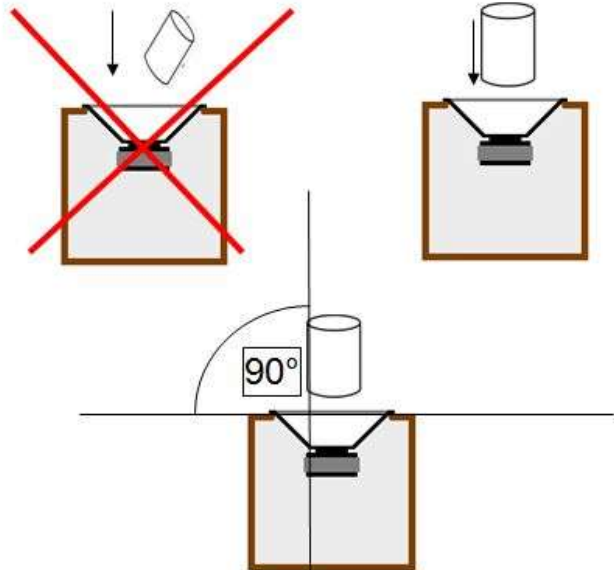

Installation

4.3.5. Normal use of the Vehicle (0 - 20)

All components of the stereo / Multimedia system should be mounted in such a manner, that the physical location does allow normal use of the vehicle and the two front seats.

The normal use of the two front seats is defined as following:



Nothing should be installed covering the darker zones.

Note to triangular windows:
If the vehicle has a triangular window and this is not higher and/or longer than half the height of the side window, it will be considered as a design element. If it is higher and/or longer than half of the height of the side window, the 4cm-rule will be applied!!!
The measurements will be taken outside of the vehicle.

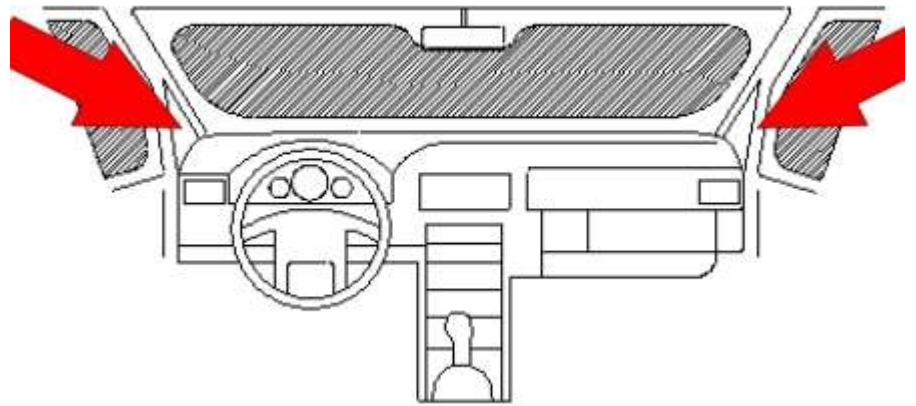

The judges will verify the normal use of the vehicle as described above. 3 (three) points deduction for each component that is interfering with the normal use of the two front seats / hiding drivers view. If components are only installed into the OEM-original locations, the competitor will receive full points.

A enclosure with more the one speaker is considered as ONE component.

How to measure the 4 cm at the windshield.

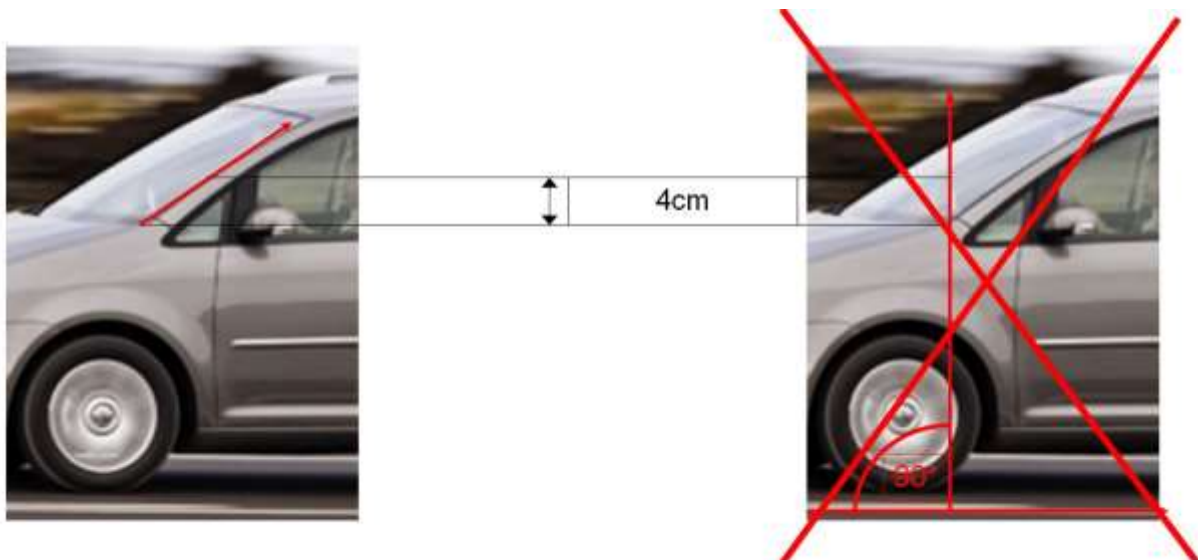
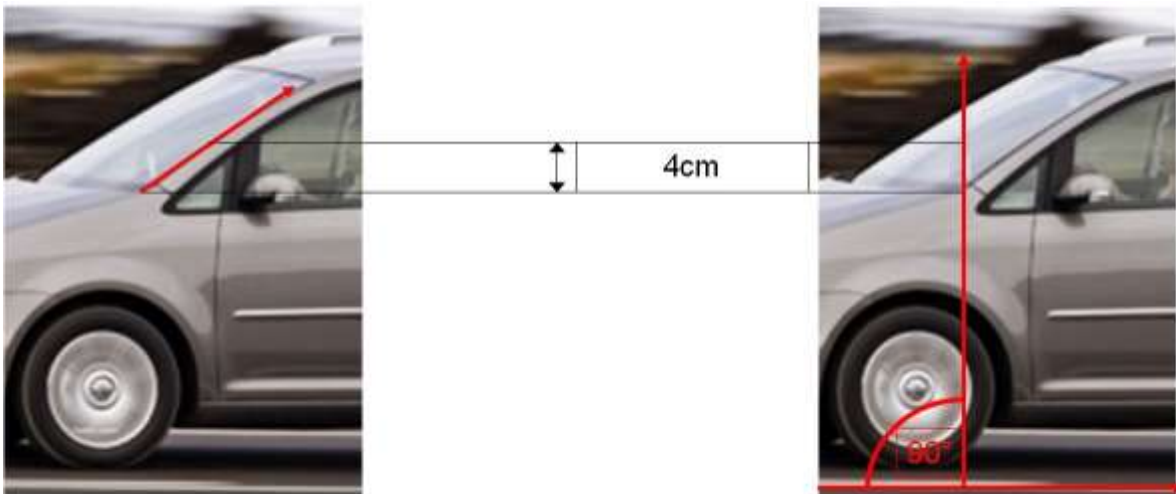

How to measure the 4 cm at the windshield.



Visibility does not include the hood



Keep in mind the 4 cm rule covers only the visibility towards road environment. No deduction if a speaker (and/or other part of installation) is e.g. is 1 cm out of 4 cm Line but only covering the car. This rule is only applicable for the windshield.

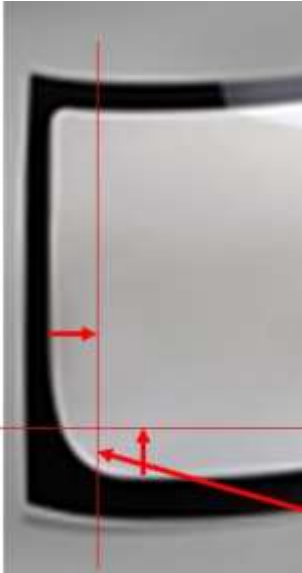

How to measure the 4 cm at the windshield.

4 cm maximum coverage
measured from the inside of the black dot,
If there are no black dots, use the point
where the field of view starts

what about this area???



not more than 50% height of the
side window is allowed



if at least one side is higher then the
explained 50% the 4 cm rules will be used
for judging the triangle window

Some vehicles may be equipped from factory with a monitor that is installed fix / moving up / swiffeling up so that it is maybe partly in the darker zone. This will not cause a point deduction. In all other cases, a monitor that is partly in the dark zone is judged as hiding drivers view and will result in a points deduction. It is up to the competitor on judges request to prove that the monitor will not hiding drives view while driving. The He adjudge can also request the physically proof.



4.3.4 Normal use of vehicle (0 – 20 points)

Drivers side	Passengers side
<ul style="list-style-type: none"> • Pedals should not be obstructed • Leg-room should allow persons (between 1,60m to 1,90m) to operate the pedals and rest the left foot • Arm-room should be enough for persons (between 1,60m to 1,90m) to turn the steering wheel • The view to the instruments should not be blocked • No part of the installation should block the view to the vehicles original side mirrors in original position. If the passenger side mirror is not factory-installed, the rear-view-mirror must allow a full view to the back 	<ul style="list-style-type: none"> • The passenger should sit comfortable (look for sub/speakers up front and / or to high raised floor) – has not to be perfect for tall passengers. But for passengers up to 1.75m. • There is no need to keep it completely original. Height of the floor and distance to wall can be different. There must be a possibility for at least 2 different but common seating positions



The passenger should sit comfortable (look for sub/speakers up front or to high raised floor) – has not to be perfect for tall passengers, but must not be smaller than the OEM foot room on the driver side between seat and pedals.



4.3.5. First optic impression (0-10 Points)

To score full points, the installation should be completed and not “under construction”. All parts should be installed decently and properly, but it doesn’t have to be extreme. A basic/simple installation, e.g. in original locations is enough for a full score. Custom panels, boxes, racks etc. should be finished, e.g. be painted or covered with cloth/fabric.

What to look for:

- Front end (0 or 2p)
- Speakers (0 or 3p)
- Amplifiers (0 or 3p)
- Other devices (as described above – 0 to 2p)

The judges will check by visual impression according to the above description.



Design

4.4.1. Design of Vehicle Passenger Department (0 – 10)

To score full points, the installation of the components belonging to the sound system and the related mounting panels, etc. should follow the same design theme. The competitor should point out during his presentation / in his documentation the ideas behind the design he has chosen for the passenger compartment of the vehicle, otherwise the judges will ask the competitor about his ideas.

Examples:

- One idea could be to keep the Interior “stock” – the competitor is trying to accomplish the impression as if his car-audio-installation is a factory option. Therefore, all visible components together with the related mounting panels, etc. should not stand out and blend perfectly with the OEM-vehicle-surrounding. Some pictures of “before” and “after” may help the judges to understand better (note: a silver source unit replacing an OEM-black one will lead to point deduction)



- Another idea could be to implement own styling ideas for the components together with the related mounting panels, etc. installed – like a styling element around all speakers, the

head unit, the remote control, etc. in the passenger compartment. The important thing is, that the theme is consequently followed through all visible components together with the related mounting panels, etc.

- Another idea could be to promote components of a certain manufacturer while other ones are not highlighted as much but also follow the basic ideas of the installation, there can be a very futuristic, rebuilt Interior, a “car-theme”, etc.

What to look for:

Front end (only the components that are used to reproduce the EMMA-recordings)

- Operator panel
- Source unit
- Black boxes
- Screens
- CD/DVD-player/changer
- External D/A converters
- Pre-Amplifiers
- Remote controls

Amplifiers

Speakers

Other Devices

- Line drivers
- Crossovers
- Signal-processors
- Additional batteries
- Multiple battery charge regulators
- Capacitors

How to score:

There will be a 2 point-deduction for each component or mounting panel not following the design-theme. The judges will evaluate, whether all the installed components of the sound system and the related mounting panels, etc. which are visible in the passenger compartment, consequently follow the idea of the competitor in a consistent way.

The judges will look for the matching of materials, surface finishes, lights (except knobs/display of components), colors etc. Significant deviations here can lead to a point deduction of up to two 2 points per component together with mounting panel.

Hidden components will not be evaluated.

The OE integration shows often that speaker different integrated. The only speakers in one view are integrated in the same way. Is this the way we should also judge?





4.4.2. Design of Vehicle Trunk Department (0 – 10)

To score full points, the installation of the components belonging to the sound system together with the related mounting panels, etc. should follow the same design theme. The competitor should point out during his presentation (or in his documentation) the ideas behind the design he has chosen for the trunk compartment. When there's any uncertainty about the design, the judges will ask the competitor about his ideas.

Examples:

- One idea could be to keep the trunk-compartment “stock” – the competitor is trying to accomplish the impression as if his car-audio-installation is a factory option. Therefore, all visible components together with the related mounting panels, etc. should not stand out and blend perfectly with the OEM-vehicle-surrounding or should be covered as OEM's. Having some pictures of “before” and “after” may help the judges to understand. (Note: visible amplifiers in a previous all black trunk will lead to points deductions)
- Another idea could be to implement one's own styling ideas for the components together with the related mounting panels, etc. installed – like a design feature around all amplifiers, speakers, etc. in the trunk-compartment. The important thing is, that the theme is consequently followed through all visible components.
- Another idea could be to promote components of a certain manufacturer while other ones are not highlighted as much but also follow the basic ideas of the installation, there can be a very futuristic, rebuilt trunk compartment, a “car-theme”, etc.



What to look for:

Front end (only the components that are used to reproduce the EMMA-recordings)

- Operator panel
- Source unit
- Black boxes
- Screens
- CD/DVD-player/changer
- External D/A converters
- Pre-Amplifiers
- Remote controls

Amplifiers

Speakers

Other Devices

- Line drivers
- Crossovers
- Signal-processors
- Additional batteries
- Multiple battery charge regulators
- Capacitors

How to score:

There will be a 2 point-deduction for each component or mounting panel not following the design-theme. The judges will evaluate, whether all the installed components of the sound system and the related mounting panels, etc. which are visible in the passenger compartment, consequently follow the idea of the competitor in a consistent way.

The judges will look for the matching of materials, surface finishes, lights (except knobs/display of components), colors etc. Significant deviations here can lead to a point deduction of up to two 2 points per component together with mounting panel.

Hidden components will not be evaluated.





Craftsmanship

4.5.1. Craftsmanship Wiring (0 – 10)

The execution and visual impression of the system wiring is judged in this section. Wiring that is not visible and is not clearly visible in the documentation cannot be considered. The judges will give their score based only on the visible/documented part of the wires.

The judges will consider the following points to evaluate craftsmanship:

- Execution of connections (crimping, soldering)
- Routing of power-, Ground-, speaker-, signal- and control-wires (nice, logical and orderly, no “knots”, etc.)
- Execution of fixing of wires (usage of wire ties and fixation in regular intervals of not more than approx. 30cm)
- Quality of wire protection (not depending on the material used, but lower points for “somehow under the carpet”, and higher points for usage of protective tubing/materials)
- Usage of shrink-hose (yes/no)
- Color-coding or labeling of wires (yes/no)
- How is the wiring made behind panels/covers
- Etc.

How to score:

4-10 points	higher efforts (suggestion: following the list above)
1-3 points	low effort
0 points	no effort

Valid for the complete judging of Craftsmanship

The value/price of the materials used is of no particular interest (e.g. no extra points for titan screws compared to steel screws, or carbon fiber compared to glass fiber). It's the looks and the quality of the work behind that is of interest.

If the internal amplifiers of the source unit are used within the system, the source unit will be judged twice, one time under "front end" and one time under "amplifiers"



4.5.2. Craftsmanship Front End (0 – 10)

The execution and visual impression of the installation of the front end is judged in this section. Components that are hidden or not shown in the documentation cannot be evaluated. The judges will give their score based only on the clearly visible/documented part of the front end. The front end is defined by those components of the installation that are necessary to read the EMMA-CD, do the digital/analogue conversion, track/volume control and provide the signal to RCA- or symmetrical outputs (all components before the Pre-amplification stage of an external amplifier):

- Operator panel
- Source unit
- Black boxes
- Screens
- CD/DVD-player / changer
- External D/A converters
- Pre-Amplifiers
- Remote controls

The judges will consider the following points to evaluate craftsmanship:

Quality of mounting (lower points for only metal slot with bend-flaps, higher points for additional struts, bolts, screws, etc. or woodscrews versa metric bolts for black boxes / CD/DVD-changers, etc. Pay special attention to mounting of black boxes)

Does the operator panel / source unit / screen / trim ring protrude (yes = lower points / no = higher points)

Quality of installation of the remote control

Using an original source unit trim ring (lower) or custom made trim ring (higher)

Gaps around trim ring to vehicle and operator panel / source unit / screen (same size all around – higher / gap size varies – lower)

Finish of front end installation (considering all above mentioned components) Etc.

How to score:

4-10 points	higher efforts (suggestion: following the list above)
1-3 points	low effort
0 points	no effort





4.5.3. Craftsmanship Amplifier (0 – 10)

The quality and visual impression of the amplifier installation, and the related mounting panels / covers is being judged in this section. Components that are not clearly visible or shown in the documentation cannot be evaluated. The judges will give their score based only on the visible/documented part of the amplifier-installation

The judges will consider the following points to evaluate craftsmanship:

- Execution of mounting of amplifiers (lower points for wood screws, higher points for metric bolts)
- Execution of mounting of mounting panels
- Fitting of and gaps around trim rings / covers (same size all around means higher points / gap size varies means lower points)
- Finish of amplifier-installation
- Etc.

How to score:

4-10 points	higher efforts (suggestion: following the list above)
1-3 points	low effort
0 points	no effort



4.5.4. Craftsmanship Speaker (0 – 10)

The quality and visual impression of the installation of the speakers and the related mounting panels / grilles are judged in this section. Components that are hidden and/or not shown in the documentation cannot be evaluated. The judges will give their score based only on the visible/documented part of the speaker-installation.

The judges will consider the following points to evaluate craftsmanship:

- Execution of fixation of speakers (lower points for woodscrews, higher points for metric bolts)
- Execution of mounting of mounting panels and grilles
- Fitting of and gaps around trim rings / grilles (same size all around means higher points / gap size varies means lower points)
- Finish of speaker-installation
- Etc.

How to score:

4-10 points

higher efforts (suggestion: following the list above)

1-3 points

low effort

0 points

no effort





4.5.5. Craftsmanship other Devices (0 – 10)

The quality and visual impression of the installation of the other devices are judged in this section. Components that are hidden and/or not shown in the documentation cannot be evaluated. The judges will give their score based only on the visible / documented part of the other devices installation.

What to look for:

Other devices

- Line drivers
- Crossovers (active or passive)
- Signal-processors
- Additional batteries
- Multiple battery charge regulators
- Capacitors

Etc. (including all other devices not mentioned above through which the audio signal will pass once it leaves the source unit until it reaches the speaker)

The judges will consider the following points to evaluate craftsmanship:

- Execution of mounting (lower = only metal slot with bend-flaps, higher = additional bolts, screws, etc. or woodscrews versa metric bolts for black boxes / CD-changers, etc. pay special attention to fixation of black boxes / hideaway units)
- Does the operator panel trim ring protrude (yes = lower / no = higher)
- Usage of trim ring that comes with other device (lower) or custom made trim ring (higher)
- Execution of fixation of mounting panels and covers
- Fitting of and gaps around trim rings / covers (same size all around – higher / gap size varies – lower)
- Finish of installation of other devices (considering all above mentioned components)
- Etc.

How to score:

4-10 points	higher efforts (suggestion: following the list above)
1-3 points	low effort
0 points	no effort

4.5.6. Overall Craftsmanship (0 – 10)

The overall quality and visual impression of the complete installation is judged in this section. Components that are hidden and/or not shown in the documentation cannot be evaluated. The judges will give their score based only on the visible/documentated part of the installation.

What to look for:

All parts that belong to or are directly depending on the mobile electronic systems installation but that are not covered under the above paragraphs for craftsmanship like:

- Quality of work behind or under covers/panels/racks
- Finish of surfaces/covers (leatherwork, paintjob etc.)
- Cracks on plastic panels
- Damages/scratches on components
- Quality of covers, panels, racks etc.
- Etc.

How to score:

0-2 points gaps
 0-2 points scratches, damages
 0-2 points leatherwork / paintjob
 0-2 points quality of work behind or under covers / panels
 0-2 points cracks

Craftsmanship Advanced/Master

In the category Master “Overall craftsmanship” will summarize the evaluation of all above-mentioned aspects within the available 10 points.

How to score:

As described in 4.5.1 to 4.5.5 with the only deviation of using a point range of 0 to 2 points per element:

0 – 2 points Craftsmanship Cabling
 0 – 2 points Craftsmanship Front end
 0 – 2 points Craftsmanship Amplifiers
 0 – 2 points Craftsmanship Speakers
 0 – 2 points Craftsmanship Other devices

Bonus**1. Bonus points (0 – 15/100 points)**

With the bonus points, the competitor has a chance to earn extra points beyond the standard installation for extra efforts taken for sound quality, Multimedia-experience and installation quality. Bonus points will only be awarded for items that are part of / connected to the car audio installation. Bonus points will only be awarded for items that are connected to the car audio installation and relevant for install judging.

Category	Points
Rookie, Experienced, Advanced and Master	No bonus points
SQ Expert OEM, 6000,, limited, MM Exp.	15 bonus points
SQ Expert Unlimited	Max 100 bonus points

The following procedure will be used for bonus points:

From the EMMA website the competitor has to download a form. On this form the competitor can fill in a maximum of 50 subjects to be scored upon to gain bonus points. Each subject will have from 0 to 3 points. Only the mentioned maximum of bonus points will be given.

How to score:

There is no "average" bonus, so each point has to be earned by the installation.

All vehicles begin at "0" points.

Maximum 3 bonus points can be earned for each element (the score can be from 1 to 3 points)

The judges have to document the exact item for which point(s) is awarded.

The competitor should specify the special details for bonus points during the presentation. The judges should not have to search by themselves for unique details.

Each detail-earning bonus must be visible or shown in the documentation.

What to look for:

Presentation besides judging (limited to maximum 6 points total):

Spectacular things that highlight components to visitors (1 to 3 points)

Special show around the car available all day (1 to 3 points)

Ergonomics (limited to maximum 3 points total):

Solutions for improving the systems ergonomics and the safety of using the system when driving will get extra points. 1 point for each detail, maximum 3 points total.

Notes:

The judges will verify the function of the remote control. The remote control should have minimum the following functions: volume, track selection and on/off (or pause/stop or mute).

Source unit/display moved from OEM-installation place for better visibility.

Custom installed steering wheel remote, not OEM/Change of OEM-remote control to operate system (not using an available interface) => to be proven by photo log.

Illuminated remote buttons

Additional remote controls for passengers

Additional displays for passengers

etc.

Sound:

Special tasks to improve SQ experience – but remember: the vehicle will be judged in the condition "as driving", curtains, window-covers, etc. are not allowed and have to be removed before judging (exception: Multimedia category) (1 to 3 points)

Bonus points can be awarded for building co-axials out of a component set, modifying of amplifiers, rebuilding the transfer of digital signals from optical to coaxial, etc...



Extraordinary craftsmanship (1 to 3 points)

Additional battery if located in the passenger compartment and connected to the system installed to sealed box (1 point)

Sealed box of additional battery located in the passenger compartment and connected to the system vented to outside (1 point)

Special efforts for serviceability of components (1 to 3 points)

Special efforts for safety of vehicle operation (1 to 2 points)

Special efforts for serviceability of vehicle, e.g. access to inside of back lights for changing light bulbs, bolts for muffler, fuel pump, etc. (1 to 3 points)

Manual for service shop how to disassemble parts of the installation (e.g. doors) for vehicle service (1 to 3 points)

Lighting of source unit matches original gauges or lighting used in other places (1 point)

Usability of trunk area (1 to 3 point for full trunk space)

Promote component longevity (1 to 3 points)

Special materials and technologies (1 to 3 points)

Special performance of installation for theft resistance (1 to 3 points) Note: an installation of an alarm system will receive no bonus points.

Inventive ideas

etc.



This Judge book is also available for download and open to any EMMA competitor. At www.carmdiaworl.com a forum for discussion about judging procedures and technical issues is available.

All further Information about EMMA is available at www.emmanet.com

Special Thanks to all who promoted us with pictures and scripts and of course to all the EMMA Industry partners for supporting the Global competition scene.

All competition rules and materials are under copyright of EMMA GmbH

Any unauthorized use is strictly forbidden



www.emmanet.com

www.emmanet.com